

H2 3000 SERIES

High Pressure, Hydrogen
Pressure Reducing Regulators



Hydrogen regulators from the Premier H2 3000 Series are piston sensed, pressure reducing regulators rated for inlet and outlet pressures up to 10000 PSIG (*689.48 bar*) and Cv of 0.04, 0.06, 0.12, 0.20.

H2 3000 Series regulators are designed for use in Hydrogen applications; they are available with a wide range of outlet and inlet configurations. Captured venting is standard.

FEATURES

- Designed for use with Hydrogen
- 10000 PSIG (*689.48 bar*) MAX
- Captured venting standard
- Cv 0.04, 0.06, 0.12, 0.20
- Numerous optional features
- Economical pricing
- Machined bar stock body, bonnet and piston eliminates porosity found in castings

SOME APPLICATIONS WILL REQUIRE A CUSTOM SOLUTION.
CONTACT PREMIER INDUSTRIES TO REQUEST A MODIFICATION
OR A CUSTOM DESIGN.

SPECIFICATIONS

- **MAXIMUM INLET PRESSURE (brass):**
 - 6000 PSIG (413.7 bar)
- **MAXIMUM INLET PRESSURE (SS):**
 - 10000 PSIG (689.5 bar)
- **OUTLET PRESSURE RANGES:**
 - 0-200 PSIG (0-13.79 Bar)
 - 5-500 PSIG (0.35-34.5 Bar)
 - 5-800 PSIG (0.35-55.2 Bar)
 - 10-1500 PSIG (0.69-103.4 Bar)
 - 15-2500 PSIG (1.0-172.4 Bar)
 - 20-3000 PSIG (1.38-206.84 Bar)
 - 25-4000 PSIG (1.7-275.8 Bar)
 - 50-6000 PSIG (3.4-413.7 Bar)
 - 100-10000 PSIG (6.9-689.5 Bar)
- **FLOW (Cv):** 0.04, 0.06, 0.12, or 0.2
- **VENT VALVE Cv:** 0.06

MATERIALS OF CONSTRUCTION

- **BODY OPTIONS:**
 - SAE 360 brass
 - 316 Stainless Steel
- **WETTED, OTHER:**
 - 316 Stainless Steel
- **SEAL OPTIONS:**
 - Viton-A®
 - Buna-N
 - EPDM
 - Other compounds available upon request
- **BACK-UP RINGS:** PTFE & PCTFE
- **MAIN VALVE SEAT :**
 - Vespel®
- **VENT VALVE SEAT :**
 - Vespel®
- **VALVE ACTUATOR STEM :**
 - Toughmet® 3 TS160U Alloy

PORTING

- **INLET/OUTLET**
 - 1/4", 3/8", 1/2" FNPT
 - 1/4", 3/8", 1/2" SAE J1926
 - 1/4", 3/8", 1/2" SAE AS5202 (MS33649**)
 - 1/4", 3/8", 9/16" MEDIUM PRESSURE

OPTIONS

- Gauges
- Private label
- Panel mounting bracket: P/N: 30-10059 (Ø2.15 panel hole)
- Panel mounting nuts: P/N: 30-10189 (Ø2.28 panel hole)
- Tamper resistant acorn nut

Vespel® and Viton-A® are registered trademarks of E.I. duPont de Nemours and Company.

ToughMet® is a registered trademark of Materion Brush Inc.

Contact factory for material certifications. Fees may apply.

PART NUMBER: H30-10206

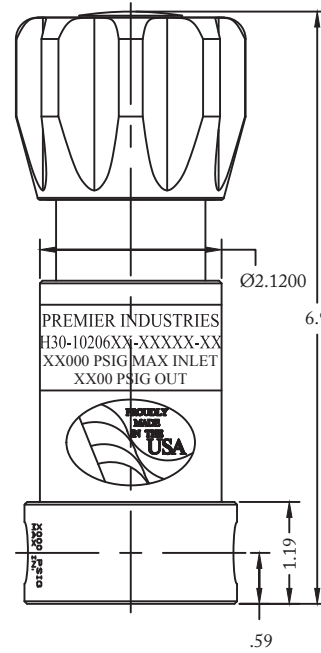
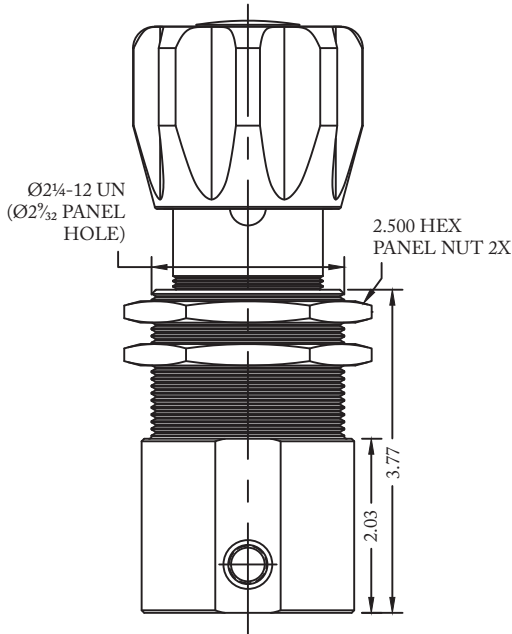

BODY DIMENSIONS		
PORT SIZE & TYPE	ØA	FLATS
NPT	Ø2.48	—
1/4" J1926, M.P.	Ø2.48	2.36
1/4" AS5202	Ø2.98	2.81
3/8" SAE, M.P.	Ø2.98	2.81
1/2" SAE, 9.16" M.P.	Ø3.23	2.98
3/8" & LARGER 'L' CONFIGURATION BODIES REQUIRE A LARGER ØA		

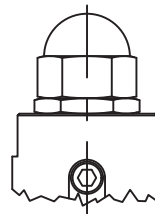
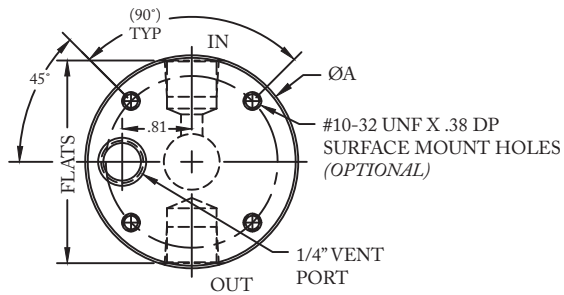





H2 3000 SERIES

High Pressure, Hydrogen
Pressure Reducing Regulators

PART #	1	2	-	3	4	5	6	7	-	8	9	-	MODS
H30-10206			-						-			-	

1 2	BODY MATERIALS (MAX. INLET PRESSURE)
MB	MOUNTING BRACKET
PN	PANEL NUT STYLE BODY
3	OUTLET PRESSURE
0	0-200 PSIG (0-13.79 Bar)
1	5-500 PSIG (0.35-34.5 Bar)
2	5-800 PSIG (0.35-55.2 Bar)
3	10-1500 PSIG (0.69-103.4 Bar)
4	15-2500 PSIG (1.0-172.4 Bar)
5	25-4000 PSIG (1.7-275.8 Bar)
6	50-6000 PSIG (3.4-413.7 Bar)
7	100-10000 PSIG (6.9-689.5 Bar)
8	20-3000 PSIG (1.38-206.84 Bar)
4	FLOW (Cv)
A	Cv 0.04
0	Cv 0.06
1	Cv 0.12
2	Cv 0.2

5	PORT SIZE
A	
C	
D	
L	
S	
6	PORT SIZE
4	1/4"
6	3/8"
8	1/2"*
9	9/16"***
*1/2" not available in medium pressure/ high pressure	
**9/16" only available in medium pressure	
7	PORT TYPE
1	FNPT
2	SAE J1926
3	SAE AS5202 (MS33649**)
4	MEDIUM PRESSURE
**SAE AS5202 supersedes MS33649	

8 9	O-RING MATERIAL
00	BUNA-N
02	VITON-A®
05	EPDM
MODIFICATIONS <i>Separate multiple mods with a dash</i>	
BLANK	NONE
ANT	ACORN NUT
B	BRASS BODY & BONNET
NV	NON-VENTING
PTU	PORT TYPE UNIFORM
SM	SURFACE MOUNT

10000 PSIG MAX INLET (Stainless Steel)
6000 PSIG MAX INLET (Brass)
The end user is responsible to ensure adequate fittings are used to connect regulator to plumbing.

Viton-A® is a registered trademark of E.I. du Pont de Nemours and Company

Contact factory for material certifications. Fees may apply.

Surface mount: pattern dependent on port type, size & configuration. -not available on panel mount style bodies.