

2510 SERIES

Diaphragm Sensed, Stable Set Pressure
Pressure Reducing Regulators



Premier 2510 Series pressure reducing regulators are part of a new family of Stable Set Pressure (SSP) regulators from Premier Industries. These single stage regulators are equipped with new technology that enables increased stability in delivery pressure and a significantly reduced supply pressure effect (*decaying inlet characteristic*). These diaphragm sensed, general purpose cylinder and line regulators are available with a wide range of materials/porting options. The Premier 2510 Series feature the choice of a neoprene or 316 stainless steel diaphragm, max inlet pressure of 3500 PSIG (*241.3 bar*) and Cv 0.20.

FEATURES

- Reduced decaying inlet characteristic (*supply pressure effect*) in a single stage design
- Cv 0.20
- 3500 PSIG (*241.3 bar*) max inlet pressure
- Machined bar stock body & bonnet, eliminates porosity found in castings
- Optional integral outlet pressure relief valve
- Economical pricing
- Optional integral needle style shut off valve
- Optional low profile hand knob
- Compact 1.5 inch diameter body option available

SOME APPLICATIONS WILL REQUIRE A CUSTOM SOLUTION.
CONTACT PREMIER INDUSTRIES TO REQUEST A MODIFICATION
OR A CUSTOM DESIGN.

SPECIFICATIONS

- **MAXIMUM INLET PRESSURE:**
 - 3500 PSIG (241.3 bar)
- **CONTROL PRESSURE RANGES:**
 - 0-10 PSIG (0 - 0.69 bar)
 - 0-25 PSIG (0 - 1.72 bar)
 - 0-50 PSIG (0 - 3.45 bar)
 - 0-100 PSIG (0 - 6.89 bar)
 - 0-250 PSIG (0 - 17.24 bar)
stainless steel diaphragm only
 - 0-500 PSIG (0 - 34.47 bar)
stainless steel diaphragm only
- **FLOW (Cv):** 0.20

MATERIALS OF CONSTRUCTION

- **BODY/BONNET MATERIAL OPTIONS**
 - SAE 360 Brass (*body & bonnet*)
 - SAE 360 Brass, Nickel Plated (*body & bonnet*)
(contact factory for pricing)
 - 316 Stainless Steel (*body*),
303 Stainless Steel (*bonnet*)
- **DIAPHRAGM OPTIONS:**
 - Neoprene
 - 316 Stainless Steel
- **O-RING SEAL MATERIAL:**
 - Nitrile
 - Viton®
 - EPDM
 - Neoprene
 - Kalrez® (*contact factory for pricing*)
- **VALVE SEAT:**
 - PCTFE
 - PTFE
- **OTHER WETTED COMPONENTS:**
 - SAE 360 Brass & 300 Series Stainless Steel
- **OPTIONAL GAUGES:**
 - 2.0" diameter, brass wetted components,
finish to match body/bonnet finish

PORTING

- **INLET:**
 - 1/8 FNPT
 - 1/4 FNPT
- **OUTLET:**
 - 1/8 FNPT
 - 1/4-18 NPT (on 1.75" and 2.0" diameter bodies)

OPTIONS

- Gauges, brass wetted components, finish to match body/bonnet finish
- Body/material finishes and diameters
- Private label
- Panel mounting nut
- Bottom mounting holes
- Pressure relief valves
- CGA connections

Viton® and Kalrez® are registered trademarks of E.I. duPont de Nemours and Company.

PART NUMBER 50-12308-2I-XX-X2-22

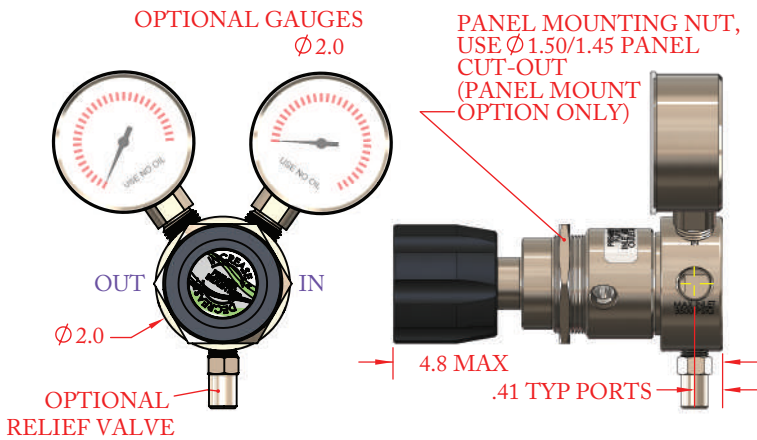



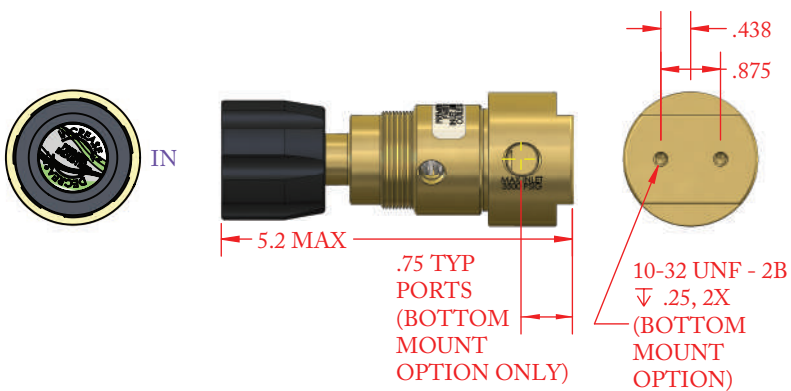







PART NUMBER 50-12308-1C-XX-X1-13



2510 SERIES

Diaphragm Sensed, Stable Set Pressure
Pressure Reducing Regulators

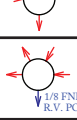
PART #	-	1	2	-	3	4	-	5	6	-	7	8	9
50-12308	-			-			-			-			

1	BODY/BONNET MATERIAL & FINISH
1	SAE 360 Brass (<i>body & bonnet</i>)
2	SAE 360 Brass, Nickel Plated (<i>body & bonnet</i>) <i>CONTACT FACTORY FOR PRICING</i>
4	316 Stainless Steel (<i>body</i>), 303 Stainless Steel (<i>bonnet</i>)
2	PORTING OPTIONS (PORTS 1/4" FNPT UNLESS OTHERWISE NOTED)
S	
A	
B	
C	
D	
E	
F	
G	
H	
I	
J	

3	MAIN VALVE SEAT MATERIAL
1	PCTFE
2	PTFE
4	O-RING SEAL MATERIAL
1	Nitrile
2	Viton®
3	EPDM
4	Neoprene
5	Kalrez® (<i>contact factory for pricing</i>)
5	OUTLET PRESSURE (outlet gauge range)
1	0 - 10 PSIG / 0 - 0.69 bar (<i>per application</i>)
2	0 - 25 PSIG / 0 - 1.72 bar (0-60 PSIG gauge)
3	0 - 50 PSIG / 0 - 3.45 bar (0-100 PSIG gauge)
4	0 - 250 PSIG / 0 - 17.24 bar (0-400 PSIG gauge) <i>stainless steel diaphragm only</i>
5	0 - 500 PSIG / 0 - 34.47 bar (0-600 PSIG gauge) <i>stainless steel diaphragm only</i>
6	0 - 100 PSIG / 0 - 6.89 bar (0-160 PSIG gauge)

6	GAUGES (see note 1)
1	No gauges
2	Include gauges
7	RELIEF VALVE (see note 2)
1	No relief valve
2	Include relief valve
8	MOUNTING
1	None
2	Panel mount
3	Bottom mount
4	Panel mount & bottom mount
9	DIAPHRAGM MATERIAL
Blank	Neoprene <i>Outlet pressure: 100 psig (6.89 bar) max</i>
S	316 Stainless Steel <i>Outlet pressure: 500 psig (34.47 bar) max</i>

NOTES:

1. INLET GAUGE ON S,D,F,G,H, & I
OUTLET GAUGE ON S,A,B,D,E,F,I, & J
2. RELIEF VALVE AVAILABLE ON PORTING
3. RELIEF VALVE AVAILABLE ON PORTING CONFIGURATION T ONLY.
RELIEF VALVE SETTING 90-420 PSIG BASED ON OUTLET PRESSURE OPTION. NOT AVAILABLE FOR 500 PSIG OUTLET.

Viton® & Kalrez® are registered trademarks of E.I.duPont de Nemours and Company. Contact factory for material certifications. Fees may apply.